

# axial check valve

fast acting non-slam protection for critical applications



# Innovate to meet

**The early days** Mokveld was founded in 1922 in Gouda, The Netherlands, as a small machine repair shop. In the mid-fifties we started making valves, a development which accelerated when the Nederlandse Aardolie Maatschappij B.V. (joint venture between Shell and ExxonMobil) discovered the Groningen gas field in 1959. Mokveld started delivering valves for the production of the billions of cubic meters of gas and over the years was challenged to respond to constant changes with respect to safety, noise and emissions. By adapting and responding efficiently to the changes of the gas and oil industry our organisation has gained an excellent reputation as an international supplier of quality valve products.

# industry demands

## Industry challenges

Mokveld is committed to contribute to safe, reliable and sustainable development of the world's energy and water resources. Our track record of satisfied customers shows our capability for selecting control solutions, designing safety systems and managing projects successfully. The axial check valves described in this brochure will help to meet your industry and project challenges.

## Worldwide experience

Mokveld has extensive experience in designing and manufacturing valves for the gas and oil industry worldwide. The product portfolio comprises a wide range of valve products, tailor-made to application and customer specifications;

### control products

- axial control valves
- axial choke valves
- angle choke valves

### safety products

- axial on-off valves (for HIPPS)
- axial surge-relief valves
- axial check valves

In addition a full range of pneumatic and hydraulic actuators with tailored control arrangements are available for accurate control and reliable operation of your process.

## Successful innovation

Regular contact with end-users and our familiarity with a wide variety of applications provide us with all the elements required for innovation. In cooperation with customers Mokveld developed stand-alone HIPPS and axial choke valves. Recently we have engineered and successfully applied innovative trim designs, subsea check valves and a new actuator line. Mokveld has extensive expertise with axial check valves in critical non-return applications.



### Mokveld headquarters

The headquarters and high tech production facilities, are located in Gouda, The Netherlands (area 14.000 m<sup>2</sup> or 150.000 ft<sup>2</sup>)



### Testing at Delft Hydraulic Laboratory

Dynamic testing is performed at the unique Delft Hydraulic Laboratory, located 20 km (12 miles) from Mokveld head office



### Dutch quality products

All engineered valve systems are tailor-made, produced and quality checked in The Netherlands



# Axial flow

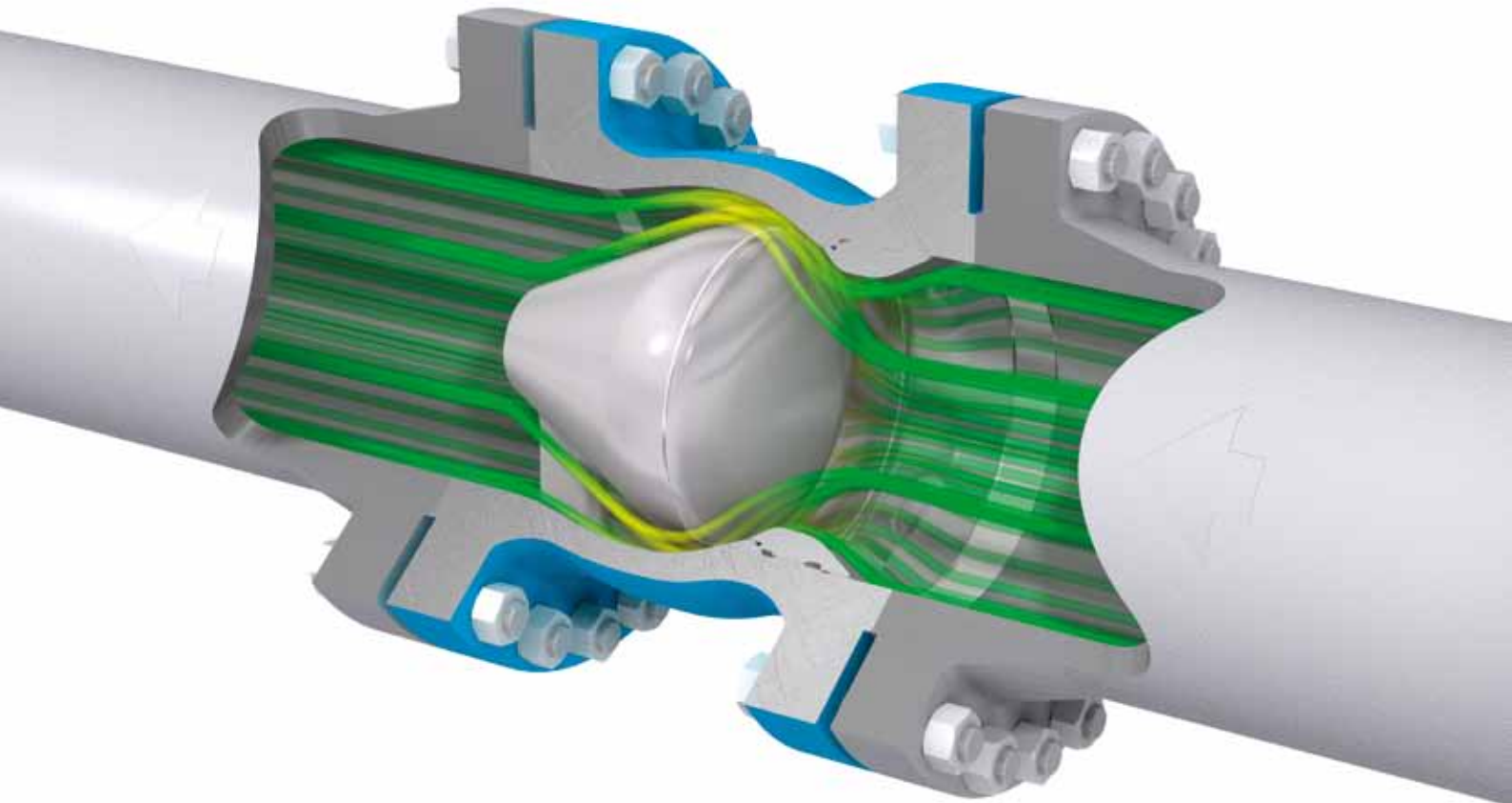

## A unique concept

Since the early 1900's an exceptional valve concept was used in hydro power plants: the axial flow valve. Axial flow refers to the streamlined symmetrical and unrestricted flow path between the valve inner and outer body. In the 1950's Mokveld acknowledged the unique advantages and adopted the concept into their on-off and control valves designs. Over the last decades those axial valves captured a strong position across the full range of gas and oil segments; production, processing, transmission, storage and distribution.

In the 1960's Mokveld engineering specialists developed the axial check valve, which is based on the same axial flow concept. Intelligent use of the venturi results in superb static and dynamic performance. Due to the outstanding dynamic performance this check valve design has also become the preferred solution for special water applications.

# a unique concept

## World class valves based on axial excellence

### Increasing safety demands

Non return valves used to be non-critical items of equipment that were originally developed and fitted to prevent downstream lines and reservoirs from draining backwards. In addition they prevented reverse rotation of pumps thereby avoiding damage to seals and drivers. The early designs were based on the concept of simple swinging flaps or discs and were usually adequate to protect low pressure and smaller systems.

The introduction of pipeline systems protected by surge protection devices, the growth in construction of larger diameter gas and liquid transmission pipelines, and the increasing importance of reducing pressure losses and consequently operating costs, has lead to drastic changes in operating requirements for non return / check valves.

### The safe solution

Mokveld check valves are sophisticated devices, carefully designed and sized to meet these new demands. They are recognized as the standard for all critical applications such as protection of rotating equipment and systems where low pressure losses are essential. Fluids handled, range from heavy crude oil to light hydrocarbon fractions, from multiphase fluids to sandloaded natural gas and from potable water to highly corrosive and contaminated produced water.

Mokveld have supplied check valves to the world's largest water and crude oil pipelines, natural gas transmission systems, gas storage facilities, LNG and olefin process plants. Mokveld check valves are used by all the major oil and gas companies, chemical industries and water transmission companies.



**20" / ASME 600 Axial Check Valve**

*Application: Gas transport*

*Challenge: Low pressure loss*

*Location: YuLin (China, 2005)*



**20" / ASME 2500 Axial Check Valve**

*Application: Compressor Station*

*Challenge: Low pressure loss and stability*

*Location: Beregovaya (Russia, 2001)*



**72" / ASME 175 Axial Check Valve**

*Application: Cooling Water Pump Discharge*

*Challenge: Dynamic response*

*Location: Bintulu (Malaysia, 1980)*



# Reliable in its

## Axial flow

Streamlined flow path through full-port body avoids turbulence and prevents erosion and vibration. Process downtime is eliminated.

## Operational benefits

## Easy opening

The low static pressure in the throat area is applied behind the disc and creates a pressure differential over the disc, resulting in easy opening.

## Stability

Extremely stable during operation. The Axial Check Valve responds smoothly to changes in flow and remains stable when it is supposed to be.

## Environmental benefits

## Reliability

The spring-assisted design ensures ultra-fast and non-slam operation without backflow and pressure surges in critical applications such as multi-pump systems.

## Tight shut-off

100%-tight shut-off is obtained by means of a metal-to-metal sealing. This sealing is not affected by erosive flow.

## Zero emission

The absence of a bonnet or any other openings to the environment ensures zero emission. Valve is fire safe and suitable for cryogenic and subsea applications.



# simplicity

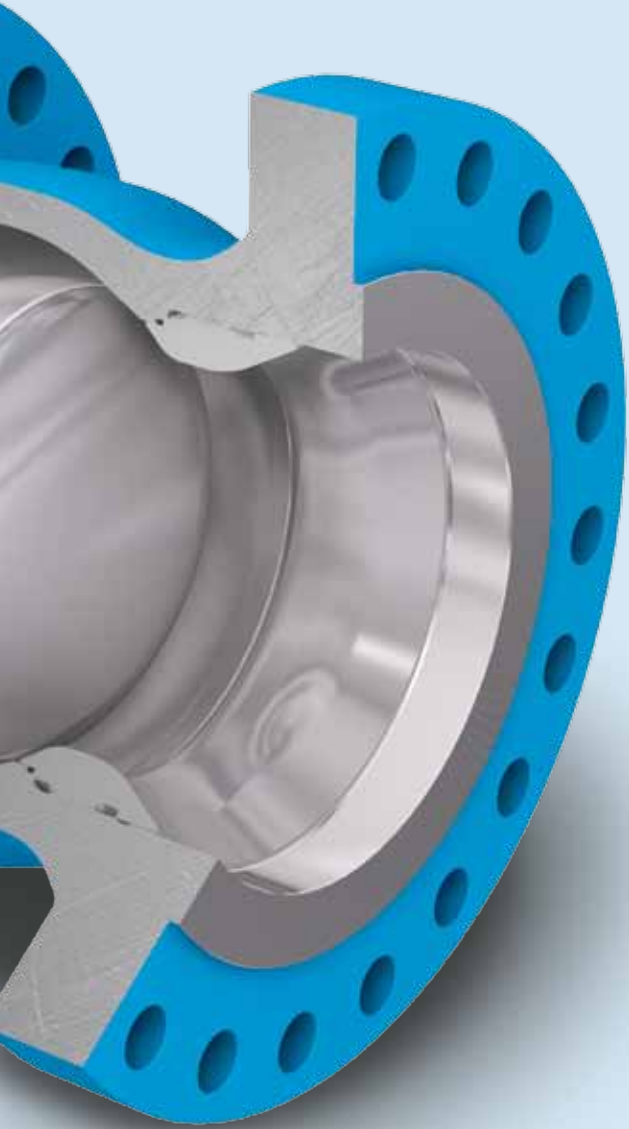

**Significant  
cost savings**

**Low  
pressure drop**

The full opening flow passage and high-pressure recovery result in very low pressure loss and thus reduced operating cost of pumps and compressors.

**No  
maintenance**

Internal construction is based on the application of sound basic mechanical engineering principles. Consequently, the Axial Check Valve does not require any maintenance.

**Compact**

The one piece valve body without bonnet provides 30 - 90% weight reduction compared to swing check valves.

# Increased reliability and

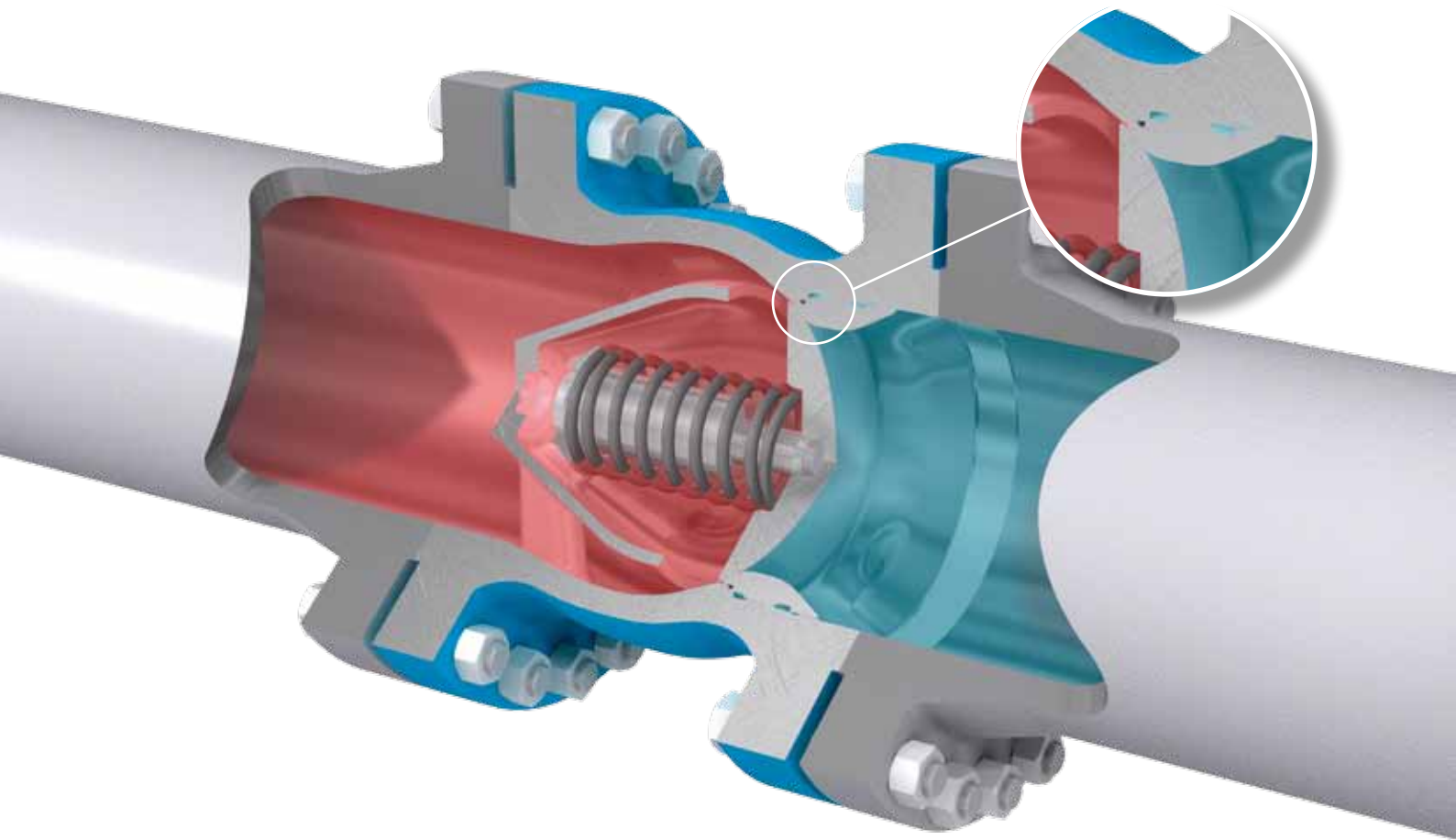

## **Safety through mechanical concept**

Valve body flanges and inner housing are combined in one single rigid casting. Internal construction is based on the application of sound basic mechanical engineering principles which eliminate the risk of loose valve components damaging rotating equipment. Mokveld check valves are certified fire safe.

## **Non-slam operation**

Due to the unique working principle the check valve responds smoothly to changes in flow and remains stable when it is supposed to be. The spring assisted design ensures ultra-fast closing without backflow and pressure surges in critical applications such as multi-pump systems.

# reduced energy loss

## Compact and maintenance free design

Various other non-return valve designs rely on external devices like counterweights and slam retarders to operate satisfactorily. Those do not allow buried installation, are space consuming and require regular maintenance. The Mokveld check valve can be buried or installed in locations where space or weight is at a premium. The Mokveld check valve normally does not require maintenance.

## Design details

The Mokveld check valve is designed to open fully at very low flow rates to minimize pressure drop during normal operation. The valve disc is connected to the disc rod which slides in bearings located in the rod guide. The spring pushes the valve closed and flow dynamic forces push the valve open. Due to the axial flow design the disc remains perpendicular to the flow at all times and therefore the area exposed to the fluid does not diminish as is the case with most non-return valves.

The design of the valve body, seat and disc results in a venturi shape which is used in three ways:

- the increased velocity of the medium in the seat area leads to a high dynamic opening force on the disc
- the low static pressure in the throat area is applied behind the disc and creates a pressure differential over the disc resulting in a strong second opening force
- the very high pressure recovery results in an extremely low overall pressure drop.

When forces from the flowing medium are lower than the spring force the valve will start closing. The selection of the spring is therefore important in critical applications such as pump discharge service. Mokveld have developed a computer program, which simulates dynamic and stationary check valve behaviour as a function of flow data provided by clients. The final result is a check valve which combines a guarantee of minimum pressure loss with optimum dynamic behaviour.



*Pressure drop over the valve in full open position is negligible*



*View through un-machined body casting showing ribs and inner-body*



*The Mokveld quality mark for custom designed valve solutions*



# Comprehensive scope

## Valve range

Our range of valve designs covers the ASME and API ratings that are commonly applied in the gas, oil and water industry, up to API 10 000 (690 barg design pressure) with related temperature ratings. Inlet and outlet connections by flanges, clamp connectors or butt weld ends can be supplied as required. The check valves can be supplied for operating temperatures from -200 °C to plus 650 °C (-330 °F to 1200 °F).

Valve diameter mm (")	Pressure rating					
	PN 20 ASME 150	PN 50 ASME 300	PN 100 ASME 600	PN 150 ASME 900	PN 250 ASME 1500	PN 420 ASME 2500
≤ 600 (24")						
≤ 700 (28")						
≤ 1200 (48")						
≤ 1600 (64")						

Larger sizes and higher pressure ratings (incl. API) upon request. The complete table with sizes and ratings can be downloaded from [www.mokveld.com](http://www.mokveld.com)

## Extensive material selection

Mokveld have many years experience in material selection for check valves in services like crude oil, natural gas, white products, olefins, multi-phase fluids, potable water, produced and seawater. The parameters included are fluid composition, velocities, operating and design temperatures and pressures. Commonly used body materials include (coated) carbon steel, austenitic stainless steels, aluminium bronze, Incoloy 825, duplex alloys, 254 SMO, etc..

## Quality and Health, Safety and Environment

At Mokveld we consider quality and health, safety and environment prime objectives for the successful completion of any project. An integrated QHSE management system focuses on continuous improvement. We aim to build customer trust and confidence through a quality of products and service that meets customers' requirements and expectations. In-house valve test facilities are available for hydrostatic and gas body and seat tests under ambient or cryogenic temperatures. All our products are designed and built in accordance with the required international standards and certified by recognized authorities such as Lloyd's and the American Petroleum Institute (API). Our valve designs comply with the standards that are most frequently used in the gas and oil industries, i.e. PED, API 6A-ISO 10423, API 6D-ISO 14313 and ASME B16.34. Next to these we are also familiar with Deutsches Institut für Normung (DIN), Norsok, Russian GOST and a variety of standards specific to certain countries, users and projects. Mokveld quality and environment management systems have been certified according to NEN-EN-ISO 9001:2008 and ISO 14001:2004. We also hold various customer and country specific certificates. A copy of our QHSE-manual can be submitted on request.

# at top quality

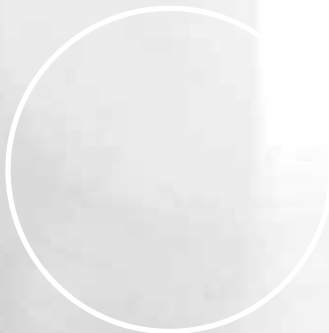
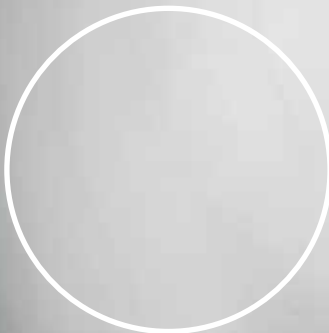

# global network - supported locally



## Mokveld Offices

- 1 Mokveld Valves BV
- 2 Mokveld USA Inc
- 3 Mokveld UK Ltd
- 4 Mokveld Norge AS
- 5 Mokveld Central Europe GmbH
- 6 Mokveld Marketing JV
- 7 Mokveld Valves BV, Middle East
- 8 Mokveld Valves BV, Saudi Arabia
- 9 Mokveld Valves BV, Asia Pacific
- 10 Mokveld Valves BV, China
- 11 Mokveld Valves BV, Algeria

## Adresses

**Gouda, The Netherlands**  
Houston (Tx), United States of America  
Cirencester, United Kingdom  
Stavanger, Norway  
Oberhausen, Germany  
Sumy, Ukraine  
Dubai, United Arab Emirates  
Al Khobar, Saudi Arabia  
Kuala Lumpur, Malaysia  
Beijing, the People's Republic of China  
Alger, Algeria

## E-mail

[info@mokveld.com](mailto:info@mokveld.com)  
[usa@mokveld.com](mailto:usa@mokveld.com)  
[uk@mokveld.com](mailto:uk@mokveld.com)  
[norge@mokveld.com](mailto:norge@mokveld.com)  
[central.europe@mokveld.com](mailto:central.europe@mokveld.com)  
[mokveld.marketing@mokveld.com](mailto:mokveld.marketing@mokveld.com)  
[mideast@mokveld.com](mailto:mideast@mokveld.com)  
[saudi.arabia@mokveld.com](mailto:saudi.arabia@mokveld.com)  
[asiapacific@mokveld.com](mailto:asiapacific@mokveld.com)  
[china@mokveld.com](mailto:china@mokveld.com)  
[algeria@mokveld.com](mailto:algeria@mokveld.com)

